

# *RS* Quest

Upgrade Kit V2



PLEASE FOLLOW INSTRUCTIONS IN CORRECT ORDER

# *RS* Quest

This upgrade for the RS Quest helps you to improve a few details of your boat. If you follow these instructions carefully, you will enjoy sailing and racing in your RS Quest even more.

## RS Quest Upgrade Pack Contents:

1x mainsail tack strap



2 x Shroud adjuster



1x improved jib tack hook



2x plastic bobble



2x neoprene boot



1x improved jib halyard shackle



1x improved reefing hook



1x bolt M5x60



2x bolt M5x16



3x M5 nut with nyloc



2x washer



## RS Quest 1 - Changing the jib tack fitting

The best way to do this is with the mast taken down. However, if you have a second person to hold the mast in position, you can do it with the mast standing up.

a)

Remove the old fitting and metal plate from the furler and the rig tension lever.

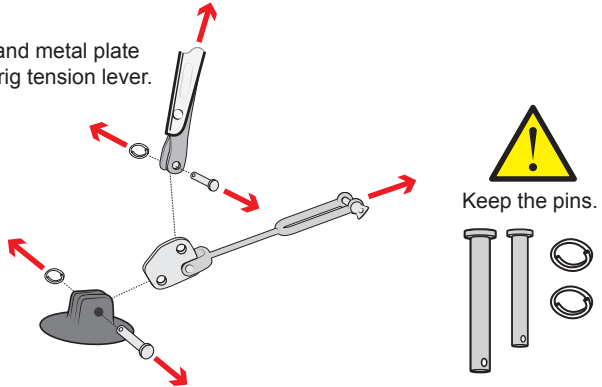

b)

Replace it with the hook, using the pins saved from **step a**.

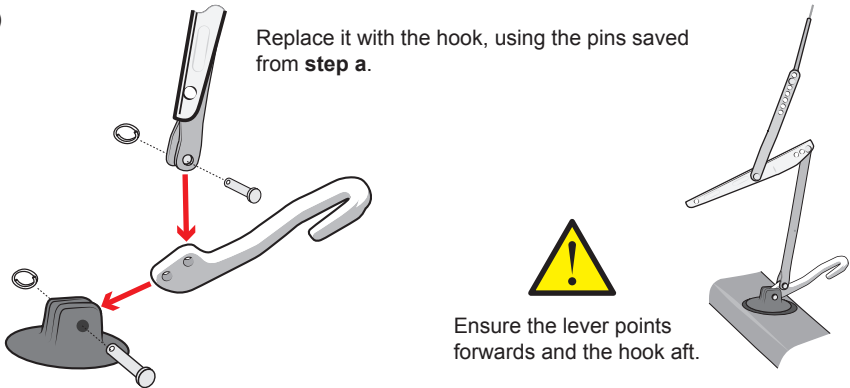

c)

To hoist the jib, just put the eye of the jib tack on the hook.

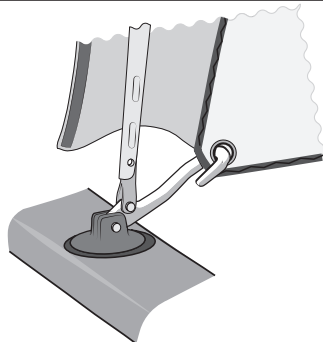

## RS quest 2 - Centreboard over rotation prevention kit

This kit consists of 2 x plastic bobbles and an M5 bolt with nyloc.

The two plastic bobbles prevent the centre board from going too far into the slot and getting stuck.

a)

Remove rope from the top hole in the centreboard.

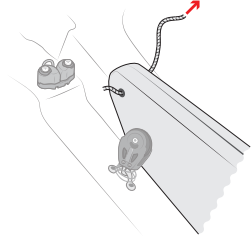

b)

Replace with M5 bolt and bobbles, one bobble on each side. Add a washer outside each bobble. Use a ratchet with an 8mm ratchet and a pozidrive screwdriver to tighten the bolt.

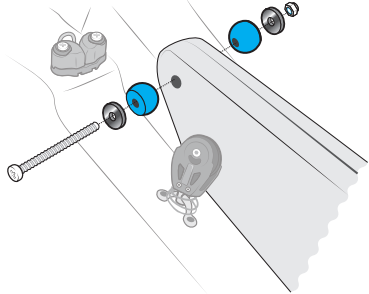

c)

To use the centreboard retainer, pass it in front of the centreboard and below the plastic bobbles.



You will need to cut the red centreboard retainer rope (with the hook on it) shorter otherwise it will pass over the Bobbles and allow the blade to rotate upwards.

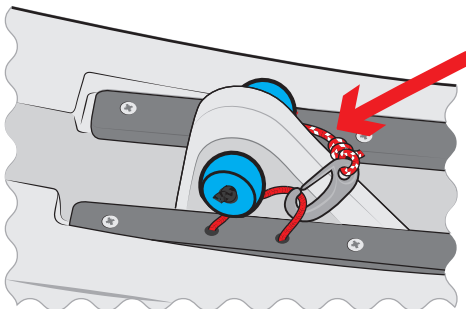

## RS Quest 3 - Shroud vernier kit

This kit consists of 2 x neoprene boots, nut and bolt and PVC tape This kit protects the shroud vernier from being damaged.

The best way to do this is with the mast taken down. However, if you have a second person to hold the mast in position, you can do it with the mast standing up.

a)

Remove the pin from the vernier.  
Remember which hole was used before.

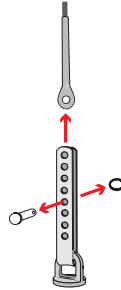

b)

Slip the neoprene boot up the shroud, pointed end to the top.

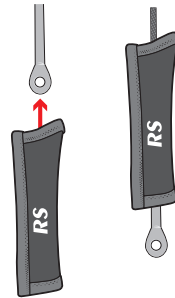

c)

Put the shroud pin back into the same hole it was before.

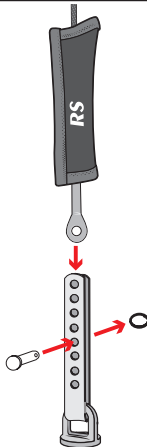

Put the 5mm bolt into the top hole of the Vernier, making sure the shroud passes outside the bolt.

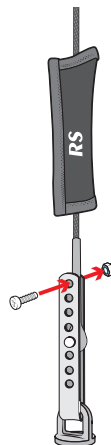

Ensure that the thread goes well into the nyloc of the nut, but do not bend the Vernier.

## RS Quest 3 - Shroud vernier kit

d)

Slide the boot down over the vernier.

Repeat **steps a - d** on the other side of the boat.



## RS Quest 4 - Mainsail tack strap

This strap helps to keep the tack of the mainsail in place.

a)

Put the strap through the tack eye of the mainsail, then strap it onto the mast.

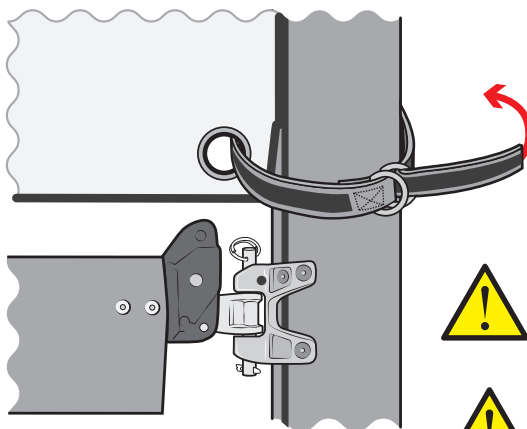

Make sure the main halyard goes under the strap to prevent it from uncleating the halyard.



The spinnaker and jib halyard need to go over the strap to minimise friction.

## RS quest 5 - Reefing hook

This new reefing hook is stronger than the old one and less likely to get caught between the boom and the mast.

- a) Remove the old hook, keep the pin and use it to install the new hook. Make sure the new hook points towards the port side.

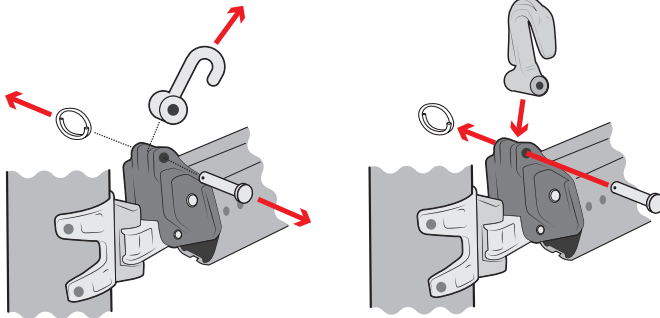

## RS quest 5 - Replacement jib halyard shackle

This shackle fits the top eye of the jib more easily.

- a)

Remove the old jib halyard shackle.

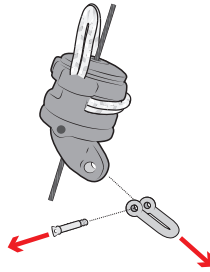

- b)

Add the new jib halyard shackle.

